

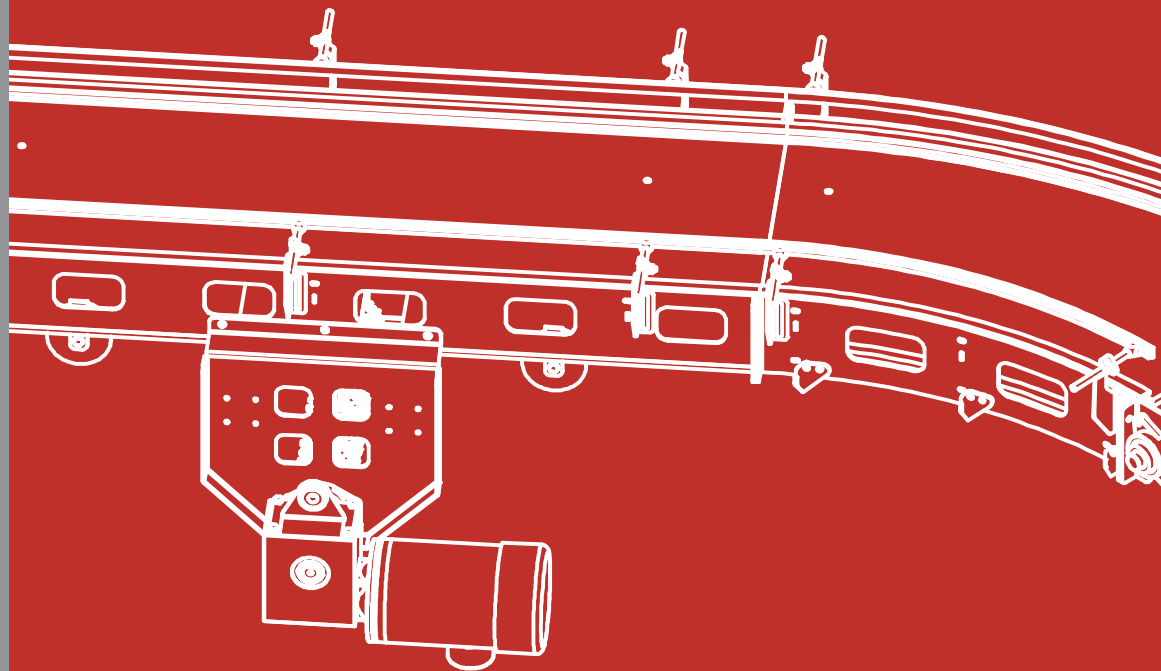

Viking Series Equipment

Material Handling Line



www.dmtbusinessgroup.com

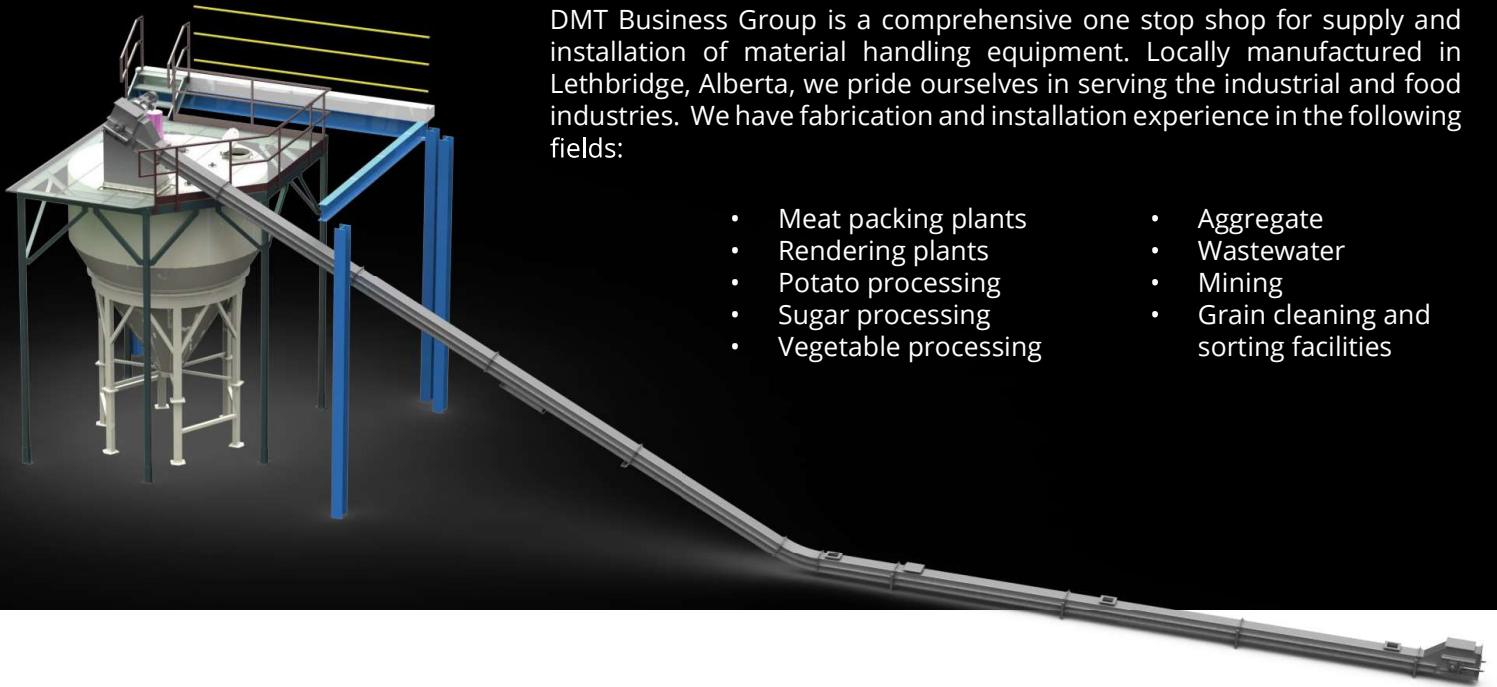

DMT Business Group is a comprehensive one stop shop for supply and installation of material handling equipment. Locally manufactured in Lethbridge, Alberta, we pride ourselves in serving the industrial and food industries. We have fabrication and installation experience in the following fields:

- Meat packing plants
- Rendering plants
- Potato processing
- Sugar processing
- Vegetable processing
- Aggregate
- Wastewater
- Mining
- Grain cleaning and sorting facilities

**Tired of long waits for your material handling needs? Expensive down time?
Drive components from other countries?**

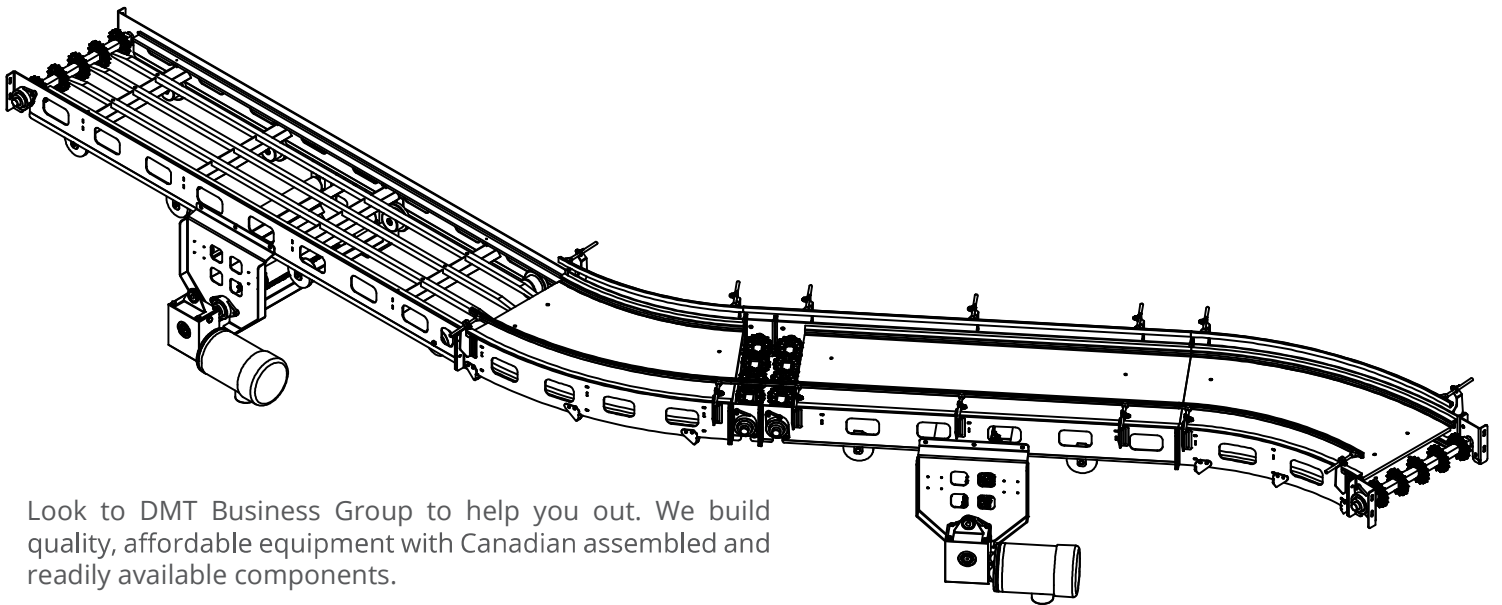

Look to DMT Business Group to help you out. We build quality, affordable equipment with Canadian assembled and readily available components.

We take our experience as fabricators and installers, and put it to work in our Viking series equipment!



Our equipment is fitted with, but not limited to, components from the following suppliers:

- Dodge Bearings
- QM Bearings
- Nord Gear Drives
- SEW Gear Drives
- Intralox Belting
- Volta Belting

We have an in-house design and drafting team to design and size conveyors and augers to your specifications. Upon inquiring you can expect a 3D drawing with a bill of materials of componentry as well as any unique details you need to make your choice.

If you are unsure of your needs, talk to one of our consultants for available options. Based on our field experience we will help direct you to the right application and components.

We have several installation sites across Alberta, Saskatchewan, and Manitoba.

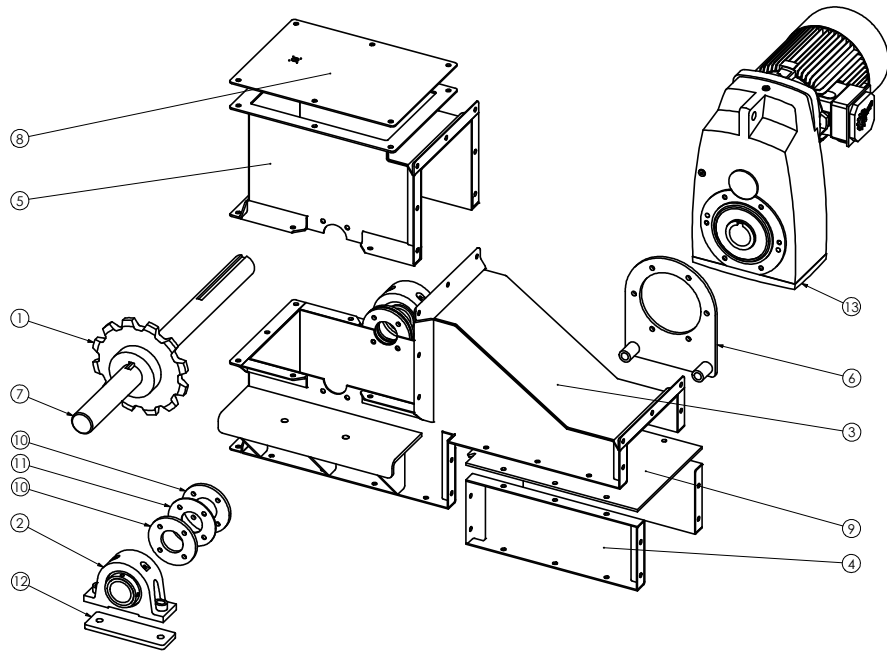

Heavy duty paddle drag

These units can be used to transport any type of dry or slurry material. This design was for spent clay, one of the most difficult materials to handle.

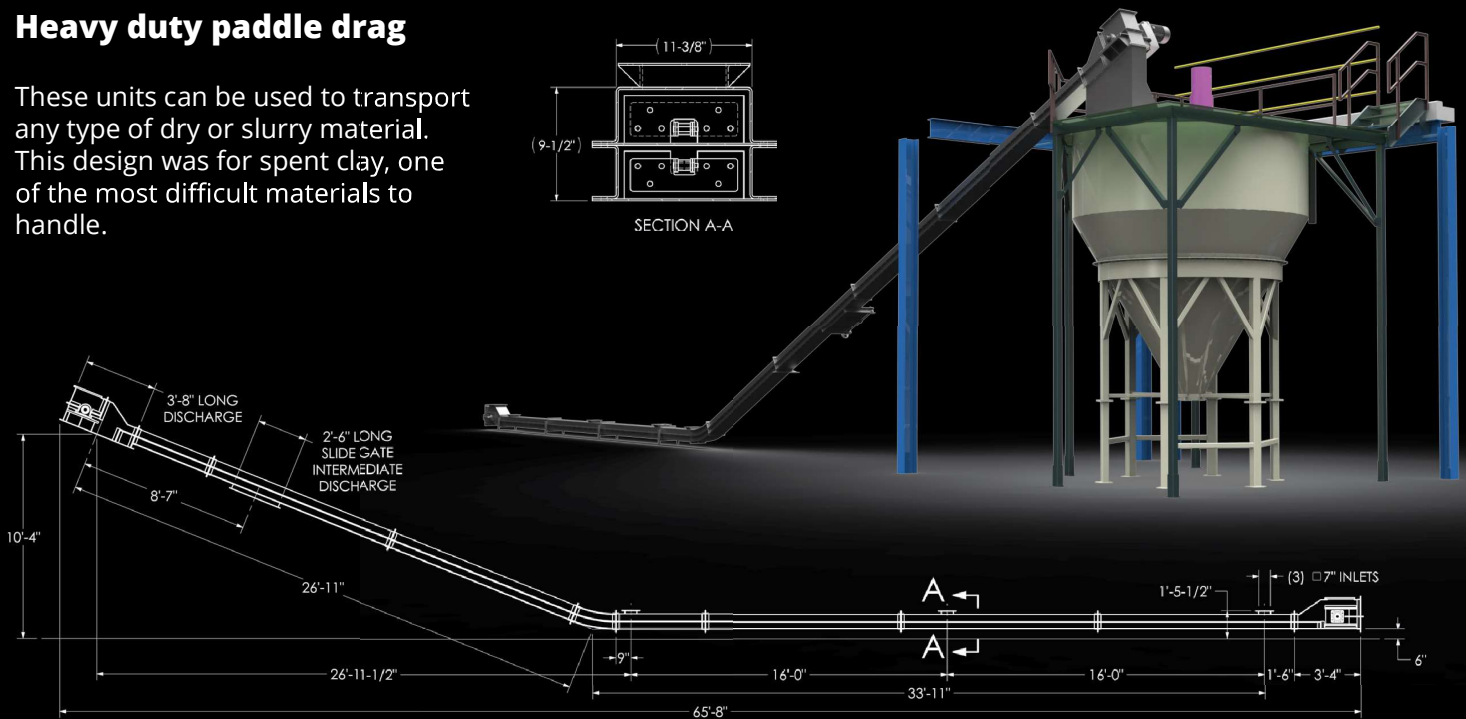
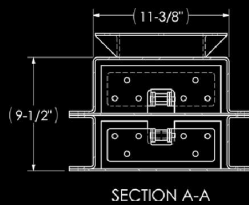



We supply overview drawings to customers for complex layouts. Our team conducts on site measurement of your space and existing equipment with the option of laser scanning. We can then input our equipment models into the digital floor plan to verify a good fit and minimize down time.

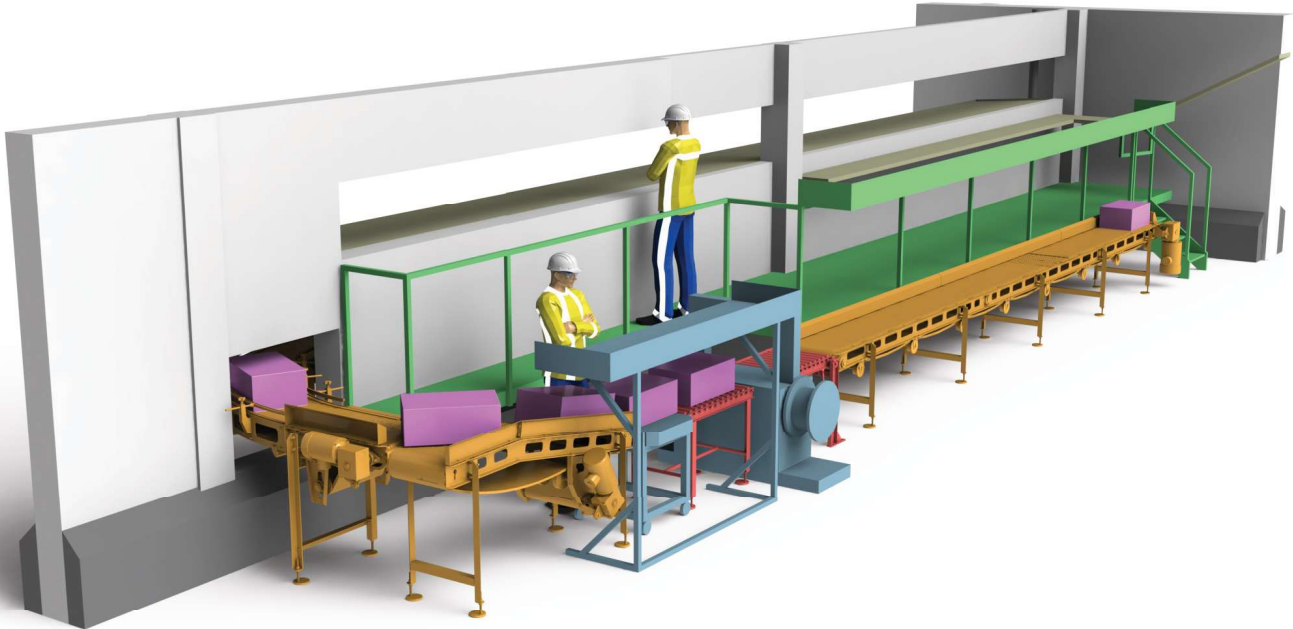
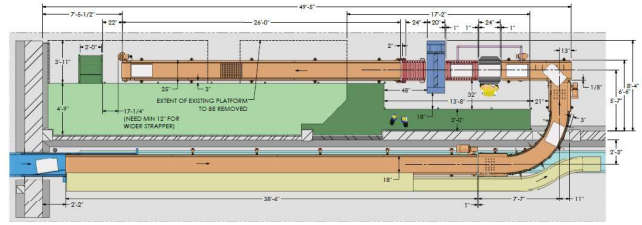

Side view of conveyors installed through a wall in a meat plant

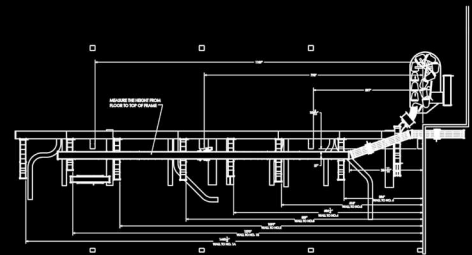
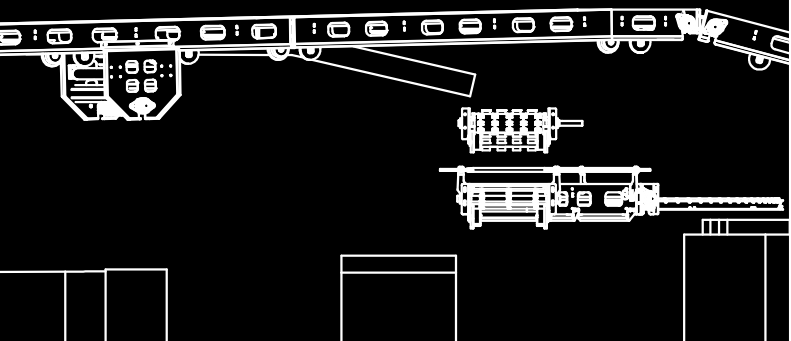

This overview of a complex packaging upgrade at a meat plant exposed potential problems which we were able to fix ahead of time.

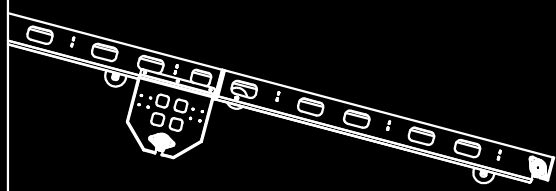

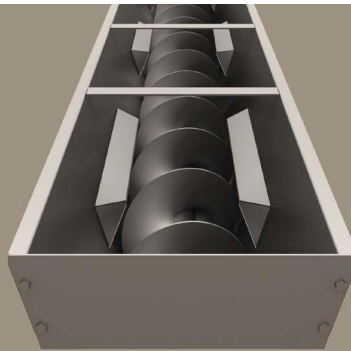

**Stainless steel 20"
rendering auger designed
and installed at a local
meat plant**

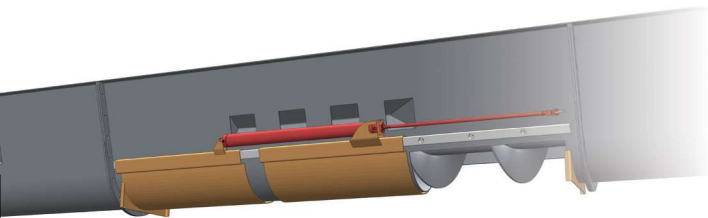

Low clearance slide gate for an auger

This design removes the step in which bone and debris often get caught. This gate discharges hooves, heads, and offal.

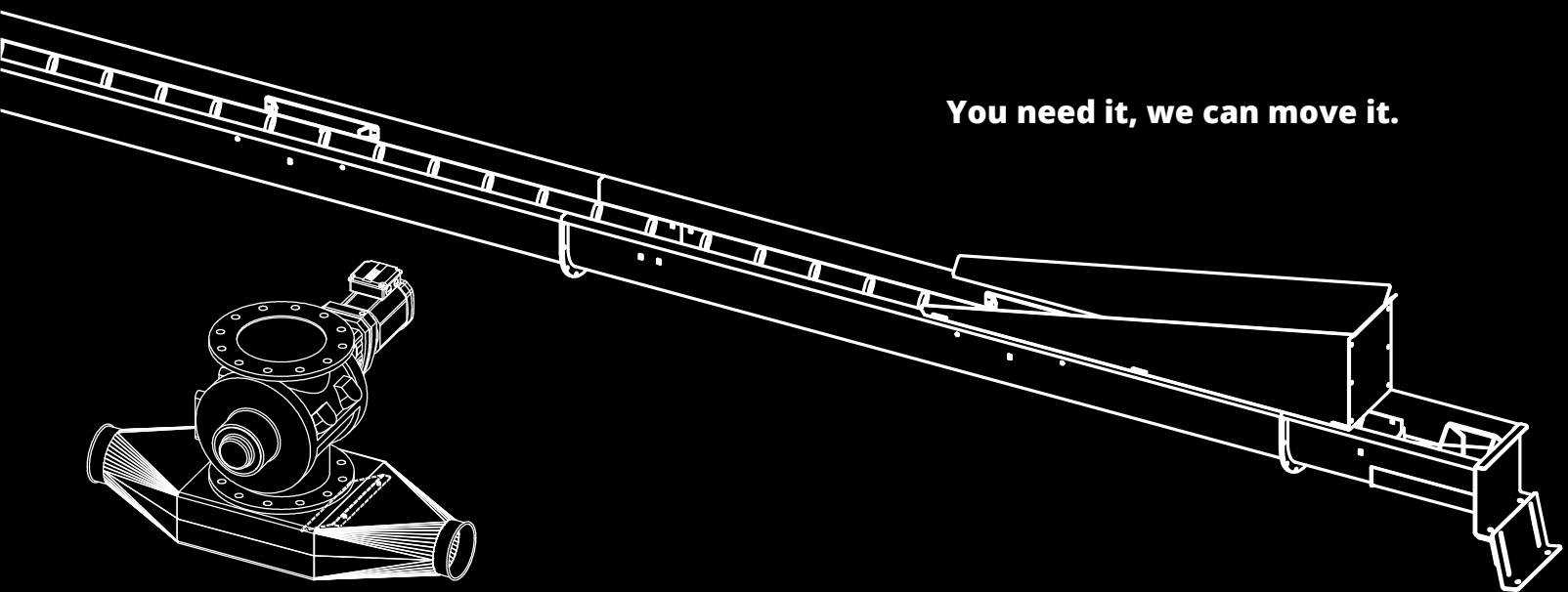

You need it, we can move it.



Viking Series Equipment

Material Handling Line

3405 16th Ave N
Lethbridge, AB T1H 5E8
Ph: (403) 328-9424



www.dmtbusinessgroup.com